

Development of the choice procedure for separation method of section iron using complex criteria of materials destruction

S.G. Karnauh

DSEA, Kramatorsk, Ukraine

Received: 25 April 2017 / Accepted: 03 June 2017

Abstract. Cluster analysis of materials destruction criteria was performed. Yield point is considered to be the most informative criterion among traditional ones. "Scale" is considered to be the most informative criterion among complex ones. Besides, complex criteria such as crack proliferation criterion and brittleness criterion are the basic informative indicators. When adding any other complex criterion (nucleation or "scale") they form the most informative sets of minimal power, providing materials classification according to their separation sensitivity with a given reliability. Taking into account the data received, recommendations for choice of separation method of section iron were developed. Value of maximum rolling plasticity, which was defined using a special method, represents an indicator, suitable for ranging rolling material according to the separation capacity.

Keywords: bending breaking, workpiece quality, separation criterion, maximum plasticity, brittle fracture, separation method.

Introduction

Measures relating to reduction of metal consumption in blank production, improvement of rolled metal separation accuracy and efficiency are prospective areas for engineering industry. These factors significantly affect technical and economical indicators of the subsequent manufacturing processes and cost of finished products in the end [1].

More than ten methods of rolled metal separation are used in blank production. They are classified according to a number of indications: waste products degree, scheme of rolled metal deformation, type of applied load etc. [2, 3]. Every known method has both advantages and disadvantages.

The most effective and promising in terms of efficiency and waste are considered to be shifting cut and bending breaking. Complex researches of waste-free methods of section iron separation were widely carried out on the enterprises of CIS countries such as Mosstankino, ENIKMASH, Voronezh enterprise for manufacturing heavy power presses (VSKBKM), Donpressmash, Kharkiv aircraft institute, Donetsk state technical university (DonSTU), Kishinev polytechnic institute, Donetsk physicochemical institute, Kommunar'sk mining and smelting institute under the guidance of Meshcherin V. T, Solovtsov S. S, Timoshchenko V. A, Finkel V. M, Roganov L. L, Borisov V. M, Vysotsky E. N and others [4-6].

The advantages of bending breaking include high efficiency and low power separation parameters. The disadvantages are: additional time for preliminary marking and making incision - application of stress concentrator and, in some cases, low quality of the separated surface (obliquity, grabs, screens) [2].

Shifting cut is also an efficient and promising method of blank production in terms of productivity and waste. The disadvantages of the method include higher energy consumption for separation and, in a number of cases, poor quality of separated workpieces [3].

Thus, the known non-waste methods for section iron separation do not guarantee high quality of the blanks, i. e. they are not universal for all steel grades, cast iron, non-ferrous metals and alloys.

Up to date, there is no method for making right separation choice and obtaining predictable positive result for materials in a wide range of mechanical properties, lengths and workpiece cross-section sizes with minimum power-intensity and high process efficiency.

The problem of workpiece production consists in opposite specifications. The solution of this problem is multiversional, the choice of one version is not obvious and it is often based on engineer's intuition and practical experience. Moreover, decision making takes place in terms of production restrictions, limits of material resources,

economic opportunities, power resources, availability of experienced personnel, transportation cost, cooperation possibility, time for preproduction, etc.

Since there is an ambiguity of problem solution for choosing the method of blank production, it is reasonable to define several alternatives and make economical analysis using special technique based on particular criteria.

The aim of the work is in development of the method for using criteria, allowing the materials to be classified according to their destruction sensitivity, namely, for choosing reasonable method of rolled iron separation into measured blanks.

As a result of conformities analysis of rolled iron forming and destructing it was brought out that development of geometric defects was caused by plastic flow during the process of separation [2, 3]. So, destruction is classified taking into account the value of preceding plastic deformation; it is called tough if destruction was preceded by considerable plastic deformation; it is called brittle if plastic deformation was less than 1...2%.

To make integrated assessment for material destruction sensitivity, the following destruction criteria were developed in the work: metal toughness factor - W_c , crack initiation criterion - K_{ci} , crack proliferation criterion - K_{pc} , brittleness criterion - P_{br} , and criterion "scale" - M .

The mentioned destruction criteria are applied for integrated assessment of workpieces material sensitivity; calculations results for different steel and nonferrous alloys (Tab. 1) are given. Materials of every criterion are ranged according to the calculated value, which makes it possible to carry out their comparative analysis.

To assess the capability of destruction criteria to define material separation sensitivity, information value of these criteria was determined. Thereto, the taxonomic problem of finding the indicators of minimal power sets in multidimensional space, which provide classification of objects with a given validity, was solved [9].

The search for solution to this problem consists in iterative sequence of performing two operations: hypothesis advancement and verification. Hypotheses advancement is performed by the algorithms of indicators choice [9]; in particular, according to the algorithm of sequential indicators addition, when one-dimensional space of n indicators is first considered, and then, on the basis of the indicator with the best value, you move to the examination of space of $(n - 1)$ indicators, etc. Informativeness verification of the obtained set of indicators is carried out by performing classification of objects and subsequent comparison of the result with the standard.

In this case, the greatest difficulty is the problem of classifying objects in multidimensional indicators space. The given problem is solved by methods of cluster analysis intended for partitioning initial set of objects into the number (or unknown number) of sets - clusters, on the basis of some criteria reflecting basic requirements of the partition [10].

Objects' clustering is performed in the multidimensional space, formed from the vectors, which components are the parameters of the objects. In this case, cluster is considered to be a group of vectors, the distance between which inside this group is less than the distance to the neighbor groups.

Because of high dimensionality of clustering tasks, one of the most effective tools used to solve them is neural networks, which are a universal means of approximation [11].

At present, there are several types of special neural networks designed to solve clustering problems. The most widespread ones are so-called self-organizing structures, in particular, Kohonen self-organizing maps (SOM) [12]. Thus, SOM may be considered to be one of the methods for projecting multidimensional space into the space with lower dimension (two-dimensional), while vectors similar to the original space turn out to be the next and on the map obtained. The scope of using SOK for clustering is limited by the tasks, in which the number of clusters is known in advance. At the same time, a fixed clusters' number, due to the rather slow weights modification, makes this algorithm more stable and capable to operate under interference and data transmission in comparison with analogues [12].

As a standard, materials clustering based on the method of expert assessments with three classes identification, was accepted. This corresponds to traditional classification of materials into being capable to supply in brittle, elastoplastic and plastic states [8]. This classification of materials is convenient when choosing the separation method.

In the cluster for materials, being in plastic state, the following ones were combined: Steel Cr3, Steel 10 (hot rolled), Steel 20 (hot rolled), Brass JIC 59-1 (see Table 1).

In the cluster for materials being in elastoplastic state, the following steel grades were combined: 10 (graded cold worked), 20 (graded cold worked), 30 (hot rolled), 40 (hot rolled), 45 (hot rolled), 45 (graded cold worked), 3X13, Y8A (See Table 1).

In the cluster for materials being in fragile state, steel of the grades 45, 40X, 65Г, 60C2, 30XГCA, ИИХ15 (hardening 860 ° C, oil, tempering temperature 550 ° C), ИИХ15 (annealing 800 ° C, air) (See Table 1) were combined.

Informativeness evaluation of classification criteria set was carried out by counting the number of coincidences and discrepancies of objects presence in the given clusters. The number of iterations in SOM construction was 7000 for every computational experiment. This ensured the stability of classification in case of total correction no more than 10-5. The application of the method of sequential indicators addition gave the following results.

Ten sets consisting of one classification criterion were obtained within the first iteration. The histogram of evaluation results of their informativeness is shown in Fig. 1. The most informative criterion among all is considered to be 1; the most informative criterion among the complex ones is considered to be 10 (see Table 1).

Table 1

Mechanical properties and synergetic criterion of metals

| Cluster | Grade of material Criterion number | σ_T , MPa | σ_B , MPa | δ , % | ψ , % | HB , MPa | W_C , MJ/m ³ | K_{ci} | N_c | K_{pc} , (MJ/m ³) ² | N_c | P_{br} , (MJ/m ³) ³ | N_c | M | N_c |
|---------|--|------------------|------------------|--------------|------------|------------|---------------------------|----------|-------|--|-------|--|-------|------|-------|
| | | 1 | 2 | 3 | 4 | 5 | 6 | 7 | | 8 | | 9 | 10 | | |
| 1 | Steel Cr3 | 240 | 433 | 32 | 62 | 131 | 397 | 1.7 | 9 | 71446 | 11 | 12860216 | 14 | 2569 | 1 |
| 1 | Steel 10 (hot-rolled) | 206 | 333 | 31 | 55 | 137 | 256 | 1.2 | 14 | 39616 | 18 | 6120638 | 19 | 2253 | 3 |
| 2 | Steel 10 (graded cold worked) | 294 | 412 | 8 | 50 | 187 | 256 | 0.9 | 15 | 56471 | 14 | 12451841 | 15 | 1105 | 9 |
| 1 | Steel 20 (hot-rolled) | 245 | 412 | 25 | 55 | 156 | 303 | 1.2 | 11 | 55756 | 16 | 10245128 | 17 | 1885 | 5 |
| 2 | Steel 20 (graded cold worked) | 287 | 471 | 30 | 63 | 131 | 441 | 1.5 | 7 | 94932 | 8 | 20434044 | 9 | 1996 | 4 |
| 2 | Steel 30 (hot-rolled) | 294 | 490 | 21 | 50 | 179 | 307 | 1.0 | 10 | 67776 | 13 | 14944704 | 13 | 1326 | 7 |
| 2 | Steel 40 (hot-rolled) | 334 | 568 | 19 | 45 | 217 | 302 | 0.9 | 12 | 75622 | 10 | 18943282 | 10 | 1009 | 10 |
| 3 | Steel 45 | 408 | 688 | 20 | 49 | 187 | 415 | 1.0 | 8 | 127088 | 7 | 38888802 | 6 | 930 | 12 |
| 2 | Steel 45 (hot-rolled) | 353 | 598 | 16 | 40 | 241 | 267 | 0.8 | 13 | 70777 | 12 | 18738229 | 11 | 800 | 13 |
| 2 | Steel 45 (graded cold worked) | 324 | 636 | 6 | 30 | 250 | 178 | 0.5 | 19 | 43256 | 17 | 10511273 | 16 | 632 | 14 |
| 3 | Steel 40X | 695 | 879 | 16 | 56 | 255 | 704 | 1.0 | 2 | 366878 | 1 | 191235256 | 2 | 543 | 18 |
| 3 | Steel 65Г | 412 | 696 | 11 | 35 | 269 | 255 | 0.6 | 16 | 78840 | 9 | 24361414 | 8 | 560 | 17 |
| 3 | Steel 60C2 | 545 | 962 | 17 | 42 | 207 | 455 | 0.8 | 14 | 185979 | 5 | 76018878 | 5 | 571 | 16 |
| 3 | Steel 30ХГСА | 490 | 794 | 22 | 63 | 229 | 725 | 1.5 | 1 | 266492 | 3 | 97935763 | 3 | 1126 | 8 |
| 2 | Steel 3X13 | 294 | 539 | 34 | 69 | 159 | 595 | 2.0 | 4 | 131222 | 6 | 28934553 | 7 | 2567 | 2 |
| 2 | Steel Y8A | 362 | 735 | 21 | 28 | 201 | 206 | 0.6 | 18 | 55803 | 15 | 15150579 | 12 | 585 | 15 |
| 3 | Steel IIIХ15 (hardening 860°C, oil, tempering temperature 550°C) | 900 | 1080 | 8 | 36 | 360 | 461 | 0.5 | 5 | 311245 | 2 | 210090435 | 1 | 212 | 20 |
| 3 | Steel IIIХ15 (annealing 800°C, air) | 487 | 692 | 25 | 61 | 207 | 637 | 1.3 | 3 | 232492 | 4 | 84917565 | 4 | 1001 | 10 |
| 1 | Brass JIC 59-1 | 235 | 392 | 35 | 43 | 101 | 215 | 0.9 | 17 | 37856 | 19 | 6672115 | 18 | 1450 | 6 |

Nine sets consisting of two criteria were obtained within the second iteration. The histogram of evaluation results of their informativeness is shown in Fig. 2. The most informative sets of criteria are considered to be 1-4 and 1-9 (see Table 1).

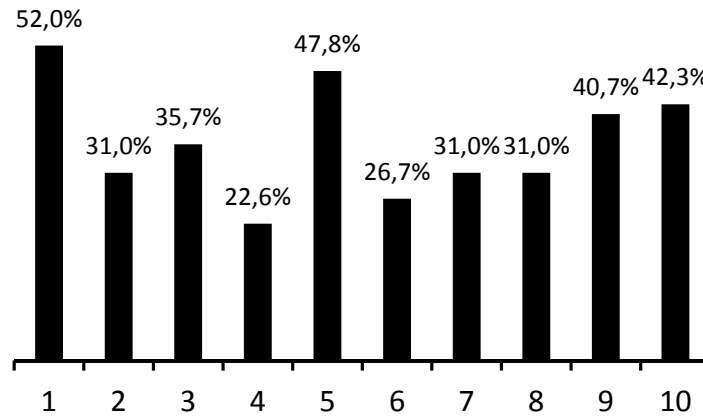

Fig. 1. The histogram of informativeness estimation of every criterion

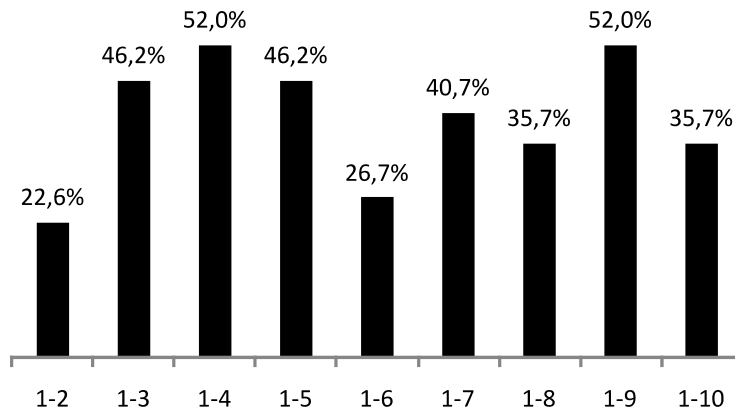

Fig. 2. The histogram of informativeness estimation of criteria pairs

In case of informativeness estimation equality, the choice of traditional mechanical properties 1-4 as the basic set of criteria results in obtaining the set 1-4-3-5-7-9-8 within the seventh iteration (see Table 1); its informativeness estimation equals 100% (Fig. 3).

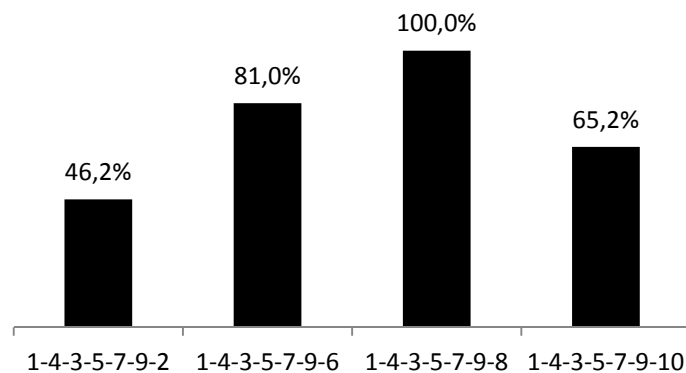

Fig. 3. The histogram of informativeness estimation of the sets based on 1-4-5-7-9 criteria

If 1-9 criteria are chosen as the basic set of criteria, the set 1-9-6-8 (see Table 1) will be obtained within the fourth iteration, which ensures complete identity of obtained clusters with the standard (Fig. 4).

When applying the algorithm of sequential indicators removal, it was found out that the set 1-9-6-8 can be reduced to the set 9-6-8 without decreasing its informative value. Further computational experiments showed that complex criteria 8-9 (see Table 1) are basic informative indicators; when any of the remaining complex criteria are added to them, they form required informative sets of minimum power.

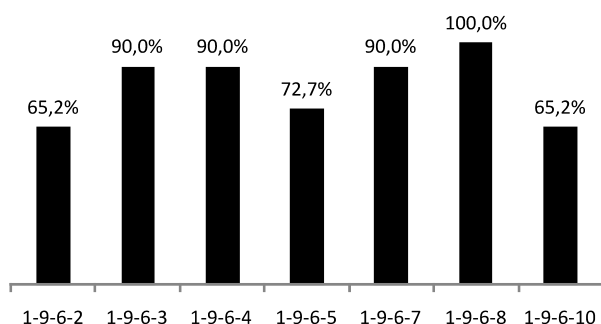

Fig. 4. The histogram of informativeness estimation of the sets based on 1-9-6 criteria

The suggested method makes it possible to choose the method of section iron separation reasonably; however, it assumes the fulfillment of the large volume of complex theoretical and experimental studies.

A simpler express method for reasonable choice of the method for section iron separation is a technique for determining maximum plasticity of rolled products when bending [13].

The method consists in preliminarily drilling a hole with the diameter d in the sample with the diameter D and the length L . Thus, the working surface along the bending line is marked with a measuring circle with the diameter d . When bending the sample, the circle of the hole turns into an ellipse, the major axis l_1 is perpendicular to the bending line and characterizes longitudinal deformation ε_1 of the surface layers; and the minor axis, located along the bending line, characterizes transverse deformation ε_2 . Having fixed l_1 , l_2 at the moment of rupture, it is easy to calculate the values of maximum plasticity:

$$\varepsilon_1^{prel} = \ln\left(\frac{l_1}{d}\right);$$

$$\varepsilon_2^{prel} = \ln\left(\frac{l_2}{d}\right).$$

Using the values of ε_1^{prel} and ε_2^{prel} it is possible to predict separation results for section iron with a certain deformation degree.

The experiment was carried out in the experimental unit DM 30M, using the original equipment according to the three-point breaking scheme (Fig. 5).

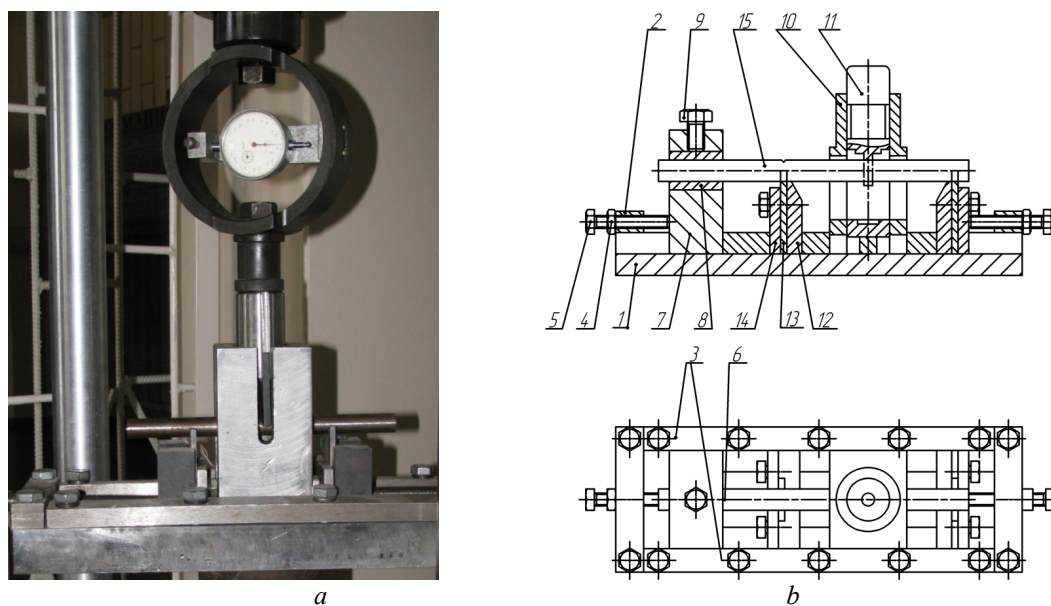

Fig. 5. Photo of the experimental unit (a) and die tooling construction (b)

Die tooling consists of the bed plate 1, mechanisms for clamping rolled metal, breaker and base are placed in its guide; they are installed making the reciprocating motion possible. This motion is limited by stops 2 and pads 3, which are fastened to the bed plate 1 with bolts. Position of the clamping mechanism, the breaker and the base is fixed with bolts 5, which are screwed into stops 2, nuts 4 and spacers 6. Mechanism of rolled metal clamping consists of the frame 7, in the hole of which a sample 15 is placed between half-sleeves 8, which are clamped with the bolt 9, which is screwed in the frame 7. Mechanism of the breaker consists of the frame 10, the breaker itself 11, which is installed making reciprocating motion in the frame guides possible. Base mechanism consists of the frame 12 and the guide plate 13, which is held by the pad 14 with the help of the bolts with washers.

Bars of the following steel grades were used as samples: 3, 20, 45, IIIX 15, which are materials in different states: plastic, elastoplastic and brittle. Sample sizes are: $D = 16\text{mm}$, $L = 80\text{mm}$. In the middle of the sample, perpendicular to the axis, a hole with diameter $d = 2\text{mm}$ was drilled (Fig. 6).

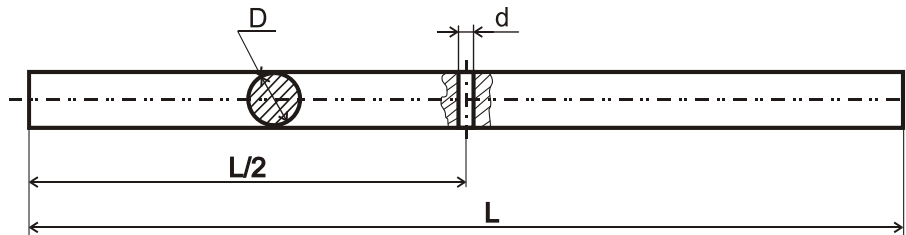

Fig. 6. Sample diagram

The sample was bent at a low deformation rate according to the three-point cold bending breaking scheme until the fracture crack occurrence, which was visually fixed.

Measuring l_1 , l_2 was carried out using the digital apparatus. Then, digital photos, which were enlarged in a computer image up to the considerable size, were processed in KOMPAS. To scale the resulting image, an additional hole $d = 2\text{mm}$ was drilled near the working deformed hole before making photo (Fig. 7).

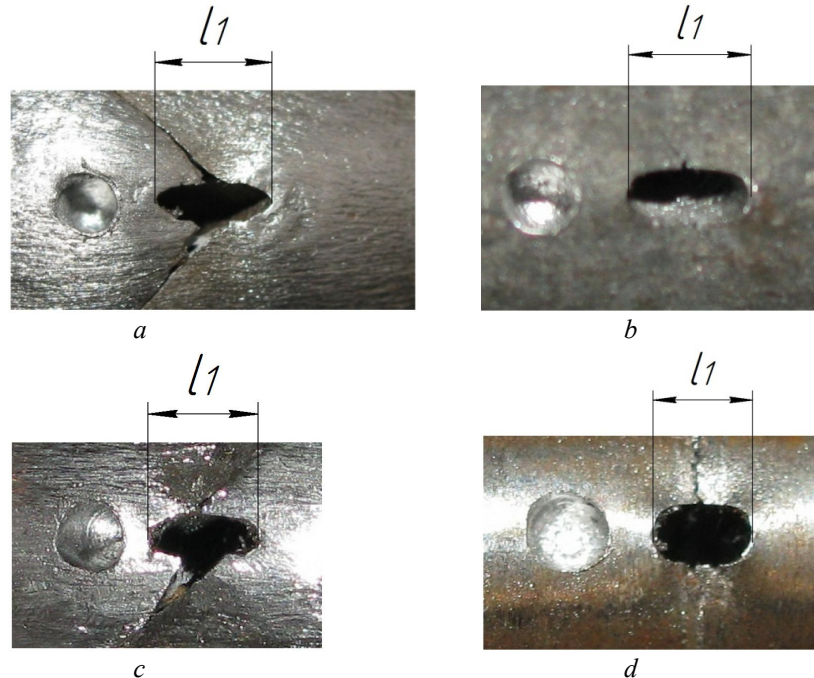

Fig. 7. Samples surfaces after bending:
a – Steel 3; b – Steel 20; c – Steel 45; d – Steel IIIX15

Bending tests are shown in Table 2.

Table 2

| Test results | | | |
|--|------------------------|------------------------|------------------------|
| Steel | Bending axis direction | ε_1^{prel} | ε_2^{prel} |
| Steel 3 | Along the rolled fibre | 0,56 | 0,39 |
| Steel 20 (hot-rolled) | | 0,50 | 0,32 |
| Steel 45 (hot-rolled) | | 0,44 | 0,22 |
| Steel IX15 (annealing 860°C, oil, tempering 550°C) | | 0,25 | 0,20 |

The results of the studies fit to the earlier conclusions drawn using complex destruction criteria.

The following steel can be rated as the cluster of materials in plastic state: Steel 3, Steel 20 (hot-rolled), for which $\varepsilon_1^{prel} = 0,50...0,56$ (see Table 2).

The cluster of materials in elastoplastic state includes Steel 45 (hot-rolled), for which $\varepsilon_1^{prel} = 0,44$ (see Table 2).

Steel IX15 (annealing 860 ° C, oil, tempering temperature 550 ° C) is rated as the cluster of materials in fragile state, for which $\varepsilon_1^{prel} = 0,25$ (see Table 2).

Conclusions:

1. Cluster analysis of materials destruction criteria was performed. The analysis led to the conclusion that the most informative among traditional criteria is considered to be the yield point, among complex ones – the "scale". Herewith, complex criteria are considered to be the following: crack proliferation criterion and brittleness criterion, which are basic informative indicators; when adding any of the remaining complex criteria (criterion of crack nucleation or "scale"), they form the most informative sets of minimum power, which provide classification of materials with stated validity according to their sensitivity to separation.

2. Taking into account the obtained results, the following recommendations can be given for choosing the method of section iron separation. The least energy-intensive method of separation, which is cold bending breaking, can be recommended mainly for separation of brittle materials from steel of the following grades: IX15, 65Г, 60С2, 50ХФА, У8А, etc., and also for separation of viscoelastic materials from steel of the grades: 45, 40Х, 30ХГСА and others, when creating the certain stress state in the destruction zone, for example, due to combined static-dynamic loading. It is reasonable to use shifting cut method for separation of viscoelastic materials in order to obtain high geometric accuracy of the workpieces. For separation of plastic materials from steel of grades: 3, 5, 10, 20, as well as copper М1, brass ЛС59-1, etc. it is advisable to use the scheme of sharing with differentiated rolled metal clamping, cutting at higher deformation speeds, cutting method in bush knives without transversal gap or cutting by off-center twisting. If an increased demand is made to the geometric accuracy of plastic workpieces, it is recommended to use complex blanking-separation processes.

3 The value of maximum rolled metal plasticity, which is determined using the original technique, represents an indicator suitable for metal ranking according to its destruction capacity. Considering the mass of section iron separation into measured workpieces one can reckon on the rapid accumulation of information about the value ε^{prel} for metals with different chemical composition and structural state, and formation of corresponding data bank.

Розробка процедури вибору способу розділення заліза за допомогою складних критеріїв руйнування матеріалів

С.Г. Карнаух

Анотація. Виконано кластерний аналіз критеріїв руйнування матеріалів. Найбільш інформативним серед традиційних критеріїв є границя текучості, серед комплексних – «масштаб». При цьому комплексні критерії: критерій розповсюдження тріщин і критерій крихкості є базовими інформативними ознаками, при додаванні до яких будь-якого з решти комплексних критеріїв (критерій зародження тріщин або «масштаб»), вони утворюють найбільш інформативну множину мінімальної потужності, що забезпечують із заданою достовірністю класифікацію матеріалів щодо їх чутливості до розділення. З урахуванням отриманих результатів розроблено рекомендації щодо вибору способу поділу сортового прокату. Величина граничної пластичності прокату, визначається за оригінальною методикою і також являє собою показник, придатний для ранжування матеріалу прокату по здатності до руйнування.

Ключові слова: ломка згином, якість заготовок, критерій руйнування, гранична пластичність, крихке руйнування, спосіб розділення.

Разработка процедуры выбора метода разделения железосодержащего железа с использованием комплексных критериев разрушения материалов

С.Г. Карнаух

Аннотация. Выполнен кластерный анализ критериев разрушения материалов. Наиболее информативным среди традиционных критериев является предел текучести, среди комплексных – «масштаб». При этом комплексные критерии: критерий распространения трещин и критерий хрупкости являются базовыми информативными признаками, и при добавлении к ним любого из оставшихся комплексных критериев (критерий зарождения трещин или «масштаб»), они образуют наиболее информативные множества минимальной мощности, обеспечивающие с заданной достоверностью классификацию материалов по их чувствительности к разделению. С учетом полученных результатов разработаны рекомендации для выбора способа разделения сортового проката. Величина предельной пластичности проката, определяемая по оригинальной методике, также представляет собой показатель, пригодный для ранжирования материала проката по способности к разрушению.

Ключевые слова: ломка изгибом, качество заготовок, критерий разрушения, предельная пластичность, хрупкое разрушение, способ разделения.

References

1. Solovcov, S. S. and Lisunec, N. L. (1990), Sostoyanie i perspektivy razvitiya proizvodstva tochnyh zagotovok iz sortovogo prokata. *Perspektivy proizvodstva tochnyh zagotovok i detalej metodami ob"emnogo deformirovaniya*. MDNTP, pp. 76–81.
2. Pickering, F. B. (2013), Metal cutting, *International Metals Reviews*, p. 202-203. <http://dx.doi.org/10.1179/imtr.1978.23.1.202>
3. Xue, W., Kusumoto, K. & Nezu, K. (2013), Relationship between plasma arc cutting acoustic and cut quality, *Science and Technology of Welding and Joining*, p. 44-49, <http://dx.doi.org/10.1179/174329305X19376>
4. Finkel', V.M., Golovin, Yu.I. and Rodyukov, G.B. (1982), *Holodnaya lomka prokata* [Cold Rolling Break], Metallurgiya, Moscow, Russia, 192 pp.
5. Solovcov, S. S. (1985), *Bezothodnaya razrezka sortovogo prokata v shtampah*. Mashinostroenie, Moscow, Russia, 176p.
6. Karnauh, S. G. (1999), Sovershenstvovanie bezothodnyh ehnergoberegayushchih sposobov razdeleniya sortovogo metalloprokata i oborudovaniya dlya polucheniya zagotovok vysokogo kachestva, Abstract of Ph.D dissertation, 05.03.05, Kramatorsk, Ukraine, 221p.
7. Roganov, L. L. (1988), Teoreticheskie osnovy razrabotki i vnedrenie ehffektivnyh kuznechno-pressovyh mashin na baze gidrouprugogo privoda, Abstract of Ph. Sc. Dissertation, 05.03.05, Kramatorsk, Ukraine, 506 p.
8. Vysockij, E. N. (1982), Issledovanie i razrabotka processa lomki prokata, Abstract of Ph.D dissertation, 05.03.05 Doneck, Ukraine, 212 p.
9. Skudnov, V. A. (2003), "Vliyanie temperatury termicheskoy obrabotki na sinergeticheskie kriterii razrusheniya stalej", *Tekhnologiya mashinostroeniya*, no. 2. pp. 6-7.
10. Karnauh, S.G., Vinnikov, M.A. and Karnauh, D.S. (2011), "Primenenie kriteriev razrusheniya materialov dlya vybora sposoba razdeleniya sortovogo prokata", *Metalloobrabotka*, Vol.1, no.61, Sankt Peterburg, Russia, pp. 25- 31.
11. Vehn Rajehin, Dzh. (ed.), (1980), *Klassifikaciya i klaster*, Mir, Moscow, Russia, p. 390.
12. Glova, V.I., Anikin, I.V. and Adzheli, M.A. (2000), *Myagkie vychisleniya i ih prilozheniya*, Nauka, Moscow, Russia, 312 p.
13. Terekhov, S.A. (1998), "Nejrosetevye informacionnye modeli slozhnyh inzhenernyh sistem", *Nejroinformatika*, Nauka, Novosibirsk, Russia, p. 101-136.
14. Debok, G. and Kohonen, T. (2001), *Analiz finansovyh dannyh s pomoshch'yu samoorganizuyushchihsya kart*. Al'pina Pablisher, Moscow, Russia, 368 p.
15. Gliner, R. E. (2008), „Opredelenie predel'noj plastichnosti polosovogo prokata pri izgibe“, *Kuznechno-shtampovochnoe proizvodstvo*, no.10, pp. 41–44.