

INVESTIGATION OF THE IMPACT OF THE NUMBER OF REPETITIONS ON THE CONTRAST OF LASER MARKINGS DURING FIELD MARKING AND DEFOCUSING OF PRODUCTS MADE OF TOOL STEEL

Лазов Любомир Костадинов, Петров Николай Ангелов
 Технически Университет-Габрово, България

ИССЛЕДОВАНИЕ ВЛИЯНИЯ КОЛИЧЕСТВА ПРОХОДОВ И РАСФОКУСИРОВКИ ЛУЧА НА КОНТРАСТНОСТЬ ПРИ ЛАЗЕРНОЙ МАРКИРОВКЕ ИЗДЕЛИЙ ИЗ ИНСТРУМЕНТАЛЬНОЙ СТАЛИ

В статье приведена информация о влиянии расфокусировки луча и числа повторяющихся проходов на контрастность получаемого изображения во время маркировки некоторой области изделий из углеродистых инструментальных сталей. Анализ результатов эксперимента показал, что выполнение одной двойной маркировки позволяет повысить скорость более чем в два раза. Приведены также результаты, направленные на определение влияния расфокусировки при применении двух волоконных лазеров, дано сравнение результатов двух лазеров, имеющих различные фокусные расстояния: над поверхностью плоскости обработки и ниже этой поверхности.

Ключевые слова: волоконный лазер, число проходов, расфокусировка.

Introduction

The contrast of laser marking on products made of tool steel is largely dependent on a number of technology parameters such as pulse power, pulse energy, speed of marking, frequency, duration of pulses, defocus, number of repeating, step, etc. All these are interrelated and, to a certain extent, influence laser marking on products. Each type of product and very often each type of tool steel require the implementation of extensive round of experiments aiming at evaluation of their importance for the specific kind of laser marking.

Presentation

The aim of this paper is to investigate the influence of the number of repeating in writing the marking areas and the influence of defocus upon the contrast of laser marking with carbon tool steels. Fiber lasers have been used as laser sources. These are innovative lasers, which have been developed over the recent years and have found wide range of applications [1] due to a number of intrinsic advantages [2, 3, 4] as compared to other lasers in various types of laser processing. Other papers authored by us [5, 6] review the impact of technology parameters on the process of laser marking.

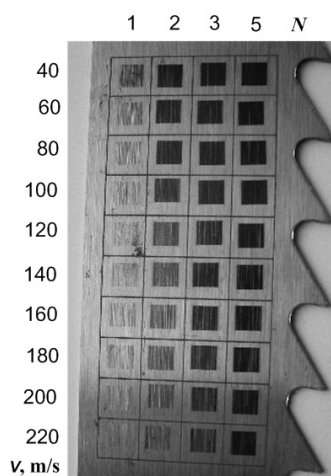

Fig. 1. Sample of tool steel Y7, marked by means of fiber laser SP – 40P

Investigation of the influence of the number of repeating N during writing of marked areas on the contrast of marking

Experiments related with the investigation of the influence of the number of repeating N upon the contrast of marking k^* have been made with finished samples of carbon tool steel Y7 with raster marking of areas of the size 3 mm x 3 mm by means of laser SP – 40P. Upon the test sample of steel have been made 40 squares of raster marking at various speeds of processing within the range of $v \in [40; 220]$ mm/s and repeating $N = 1; 2; 3; 5$. Figure 1 presents a photo of the sample after the completion of the experiment.

The graphs of the experimental dependence $k^* = k^*(v)$ for various number of repeating are presented on fig. 2. Parameters which remain constant during impact are presented by a rectangle on the graph.

Drawing on the experimental results the following conclusions could be made:

- The rise in the number of repeating causes deeper contrast in the laser marking;
- With variation of speed within the interval $v \in [40, 100]$ mm/s during double raster marking of lines, contrast k^* increases $\sim 2,5 - 3$ times as compared to single marking (graph chart 1 and graph chart 2 on fig.2). The explanation for this experimental result is that due to the first treatment absorption capacity within the impact zone is increased. Thus a second treatment in the zone will absorb more energy from the falling laser radiation.

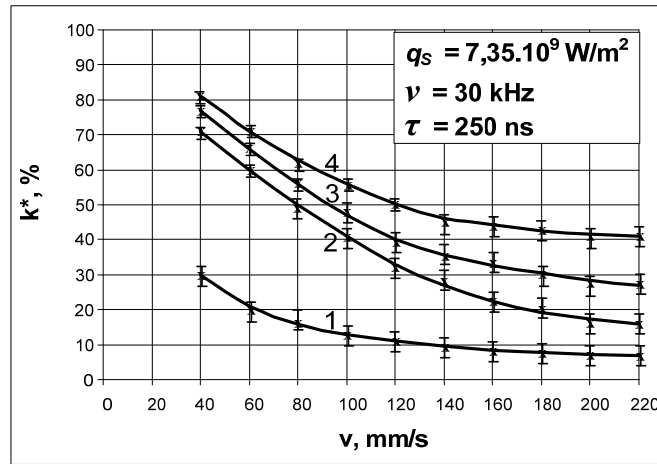

Fig. 2. Graphic chart of the experimental dependence $k^* = k^*(v)$ for marking with fiber laser SP - 40P for number of repeating: 1 – $N = 1$; 2 – $N = 2$; 3 – $N = 3$; 4 – $N = 5$

- For a number of repeating $N = 3$ and $N = 5$ a greater contrast k^* of the marked zone is achieved as compared to the one for $N = 2$, however, the increase is insignificant, only 5-10%. This result indicates that there is no need to make a greater number of repeating for the investigated types of steel than $N = 2$ since that demands extra time and energy which raises the production cost whereas the quality of marking does not improve noticeably.

- From the presentations of graph charts (1) and (2) it is evident that the effectiveness of raster marking during second treatment of the work zone is much greater as compared with single treatment. For speeds of processing 80 and 120 mm/s is achieved contrast k^* with values 50% lower than those achieved with single raster marking of zones for the same time of impact with 40 and 60 mm/s respectively.

A second series of experiments were made for the purpose of investigating the variation of contrast k^* during single marking and double marking but at twice as high speed as with single marking. In this way both types of marking are done for the same time and with the same amount of energy falling on the samples. Power density of laser radiation during these experiments varies within the interval $q_s \in [0,95 \cdot 10^{10}; 1,91 \cdot 10^{10}]$ W/m² with a step of $0,16 \cdot 10^{10}$ W/m². The values of the other parameters are given in table 1.

Table 1

Number of markings Parameter	Single	Double
Speed of marking v , mm/s	60	120
Frequency ν , kHz	30	30
Duration of pulses τ , ns	250	250
Diameter of work spot d , μm	35	35

Analysis: From graph 1 and graph 2 of fig. 3 it is evident that for double marking of areas at speed two times higher than with single marking, there are larger values of the contrast as compared with single marking (the difference being 5-8%). During single marking only $(1 - R)$ part of laser radiation with energy E is absorbed. During double marking at two times higher speed, the energy falling upon samples is the same as with single marking, however, much larger part of it is absorbed as compared with single marking. With first marking half of the energy (power) is absorbed. The coefficient of reflection decreases and becomes $R' < R$ whereas during second marking again half of the amount of energy (power density) falls and only $(1 - R')$ is absorbed. Thus the absorbed energy is $\left(1 - \frac{R + R'}{2}\right)E$,

which is considerably larger than the one used for single marking $(1 - R)E$.

In order to achieve marking with maximum contrast k^* in double marking of areas, there is used less energy (power density) as compared with single marking. Double marking is more economic in terms of energy consumption and is reflected by the prime cost of the product.

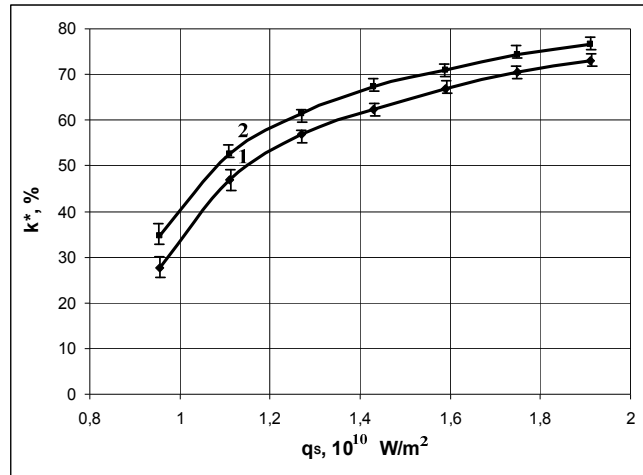

Fig. 3. Graph charts of the experimental dependence $k^* = k^*(v)$ during marking with fiber laser SP – 40P done on sample of carbon tool steel Y11: 1 – single marking; 2 – double marking

Investigation of the defocus influence Δf with raster marking

To achieve proper manufacturing performance it is necessary that the laser radiation be directed and focused on the treated surface. The minimum diameter of the focal spot d_f is defined by the expression

$$d_f = M^2 \frac{4\lambda}{\pi} \frac{f}{D}$$

where f is the focal distance; D - is the diameter of radiation.

When the focus is above the surface of the sample or is immersed in the material (work is performed at defocus) then the diameter of the work spot is increased. Samples made of carbon tool steel type Y10 were used for the purpose of investigating the influence of defocus on the contrast of marking. Experiments have been conducted in two modes:

- the focus being above the treated surface;
- the focus being immersed in the sample.

Experiments with the focus being immersed in the material were made with fiber laser SP – 40P and fiber laser UF - 20. Lenses of various focal distances have been used in order to find out the influence of this parameter upon the contrast of marking. The samples used are made of carbon tool steel type Y10 with finished surface. Defocus varies within the interval $\Delta f \in [0; 4]$ mm at every 0,5 mm, whereas parameter values, which are kept unchanged during the experiments are given in table 2. Two series of ten fields each and size 3mm x 3mm are marked by way of raster

Table 2

Type of laser	SP – 40P	UF – 20
Parameter		
Rated power of laser beam P , W	14	16,6
Speed of marking v , mm/s	90	90
Frequency ν , kHz	30	20
Duration of pulses τ , ns	250	100
Diameter of work spot d , μm	30	40
Focal distance f , mm	160	254

Experimental results for dependence $k^* = k^*(\Delta f)$ concerning carbon tool steel samples used for raster marking are given in fig. 4, graph 1 is about fiber laser SP - 40P; and graph 2 is about fiber laser UF – 20. By analyzing the outcomes the following conclusions are made:

- Contrast decreases until reaching almost linear value when defocus is increased. It is due to the enlarged diameter of the treated spot and, consequently, to the rapid drop in the power of the beam (q_s is inversely proportional to the diameter d of the work spot);

The rate of contrast decrease within the interval of defocus variation $\Delta f \in [0,6; 4]$ mm is 10,7 %/mm for fiber laser UF – 20 and 13,4 %/mm for fiber laser SP - 40P. The reason for the different speeds of contrast decrease is in the different focal distances of both laser systems - $f = 254$ mm for fiber laser UF – 20 and $f = 160$ mm for fiber laser SP - 40P. With the first system the increase in defocus causes slower increase in the diameter of the treated spot and therefore the power density of the laser beam will drop more slowly;

The evident plateau(flat section of the graph) in the interval $\Delta f \in [0; 0,3]$ mm ($k^* = 71\%$) for fiber laser SP - 40P and in the interval $\Delta f \in [0; 0,6]$ mm ($k^* = 65\%$) for fiber laser UF – 20 is explained by the fact that marking takes place in the of Rayleigh where the treated spot diameter is almost unchanged.

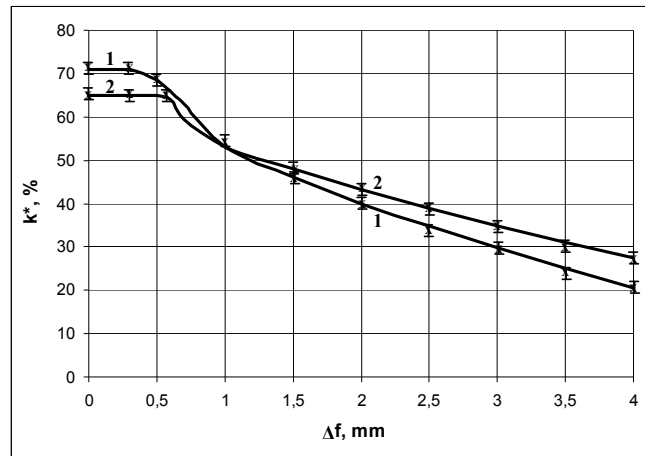

Fig. 4. Experimental dependence $k^* = k^*(\Delta f)$ for carbon tool steel type Y10with: 1 - fiber laser SP – 40P; 2 – fiber laser UF – 20

The second series of experiments are made with defocus variation within the interval $\Delta f \in [-3; 4]$ mm at every 0,5 mm for fiber laser; the focus being above the treated surface for the interval $\Delta f \in [-3; 0]$ mm while for the interval $\Delta f \in [0; 4]$ mm the focus is immersed in the material.

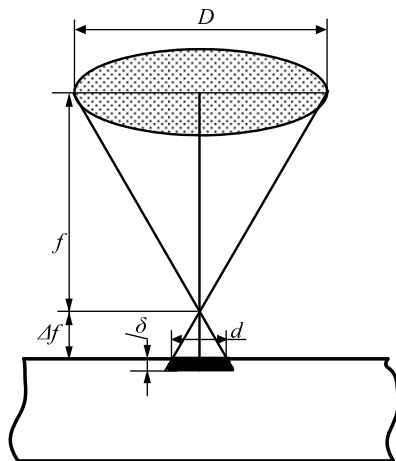

Fig. 5a

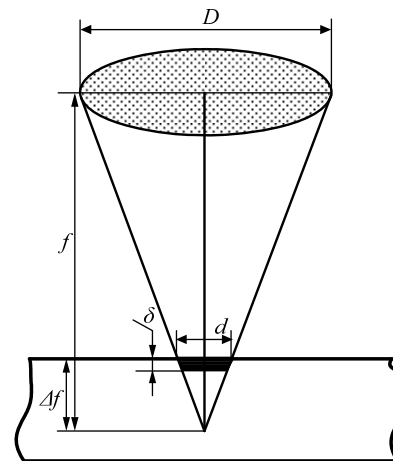

Fig. 5b

In figures 5a and 5.b black strips indicate the volumes within which laser beam is absorbed for either case. The diameter of the treated spot is indicated by d for both cases and δ indicates the depth of laser beam penetration. What is obtained are two truncated cones, however, when the focus lies on the surface, the result is a truncated cone whose smaller diameter has dimension d , whereas when the focus is immersed in the sample the resultant truncated cone has d as its larger diameter. For either of the reviewed cases the depth of penetration remains the same which leads to the conclusion that for the first case energy is absorbed by a larger bulk of the material as compared to the second one. Calculations indicate that the difference in the size of these bulks is about 5% and therefore has negligible influence on the contrast of marking.

Analysis: From experimental results (fig. 6) follows:

- With defocus increase by absolute value, the contrast of marking will decrease for both cases.
- The curve for the focus which is above treated area is steeper as compared to the other case. The speed of decrease in contrast is 20,3 %/mm within the interval $\Delta f \in [-3; -0,5]$ mm and 13,4 % mm in the interval $\Delta f \in [0,5; 4]$ mm. This is due to the following reason: when the focus is above the surface, part of the air becomes ionized and these results in the indirect impact on behalf of the resultant plasma cloud. Losses result from the radiation of the cloud. When the focus is immersed in the material, laser radiation is absorbed by the free electrons in the very thin surface layer. With the rise of temperature in the treated zone the absorption capacity of the material is also rising which in turn enhances the contrast of marking as compared with the case when the focus is above the treated surface;

- Contrast maximum is obtained when treatment takes places in the zone of Rayleigh; the result being in conformity with the supporting theory [7].

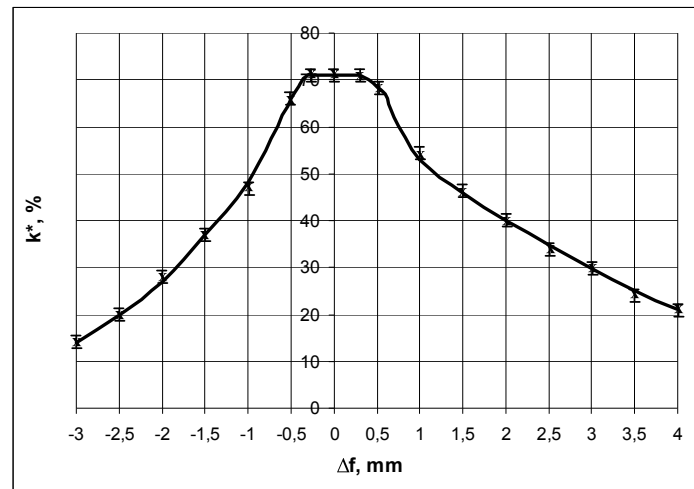

Fig. 6. Graph of the experimental dependence $k^* = k^*(\Delta f)$ of carbon tool steel Y10 with fiber laser SP - 40P

Conclusion

Proper evaluation of the impact of various technological parameters on the contrast of marking made on products of carbon tool steel contributes to the optimization of the manufacturing process and enhances the effectiveness of their production.

Анотація. В статті приведена інформація про вплив расфокусування лазерного пучка та числа повторюваних проходів на контрастність отриманого зображення в час маркування певної області виробів з углеродистих інструментальних сталей. Аналіз результатів експерименту показав, що виконання однієї подвійної маркування дозволяє підвищити швидкість більш ніж в два рази. Приведені також результати, направлені на визначення впливу расфокусування при використанні двох волоконних лазерів, дано порівняння результатів двох лазерів, які мають різні фокусні відстані: над поверхнею площини обробки та нижче цієї поверхні.

Ключові слова: лазерне маркування, інструментальні сталі, контраст

1. Major Findings of the FIBER LASER REPORT 2009 Press Release March 3, 2009, www.optech-consulting.com
2. Гладких Ю., Волоконные технологические лазеры и оценка эффективности их применения, ЭНТИ Наука и образование, 2008
3. Дианов Е.М., Волоконные лазеры, УФН, Конференции и симпозиумы, т. 174, № 10, с. 1139-1142, 2004
4. Techel A., Faserlaser steigern die Geschwindigkeit vieler Bearbeitungsprozesse, 2007, Maschinen Markt, www.maschinenmarkt.vogel.de/themenkanale/produktion-verbindingstechnik-articles-4617
5. Лазов Л., Н. Ангелов, Основни фактори, определящи качеството на маркировка на метали и сплави, Международна научна конференция Амтех'07, Габрово, том I, с. 102-107, 2007
6. Лазов Л., Н. Ангелов, А. Атанасов, Оптимизация на параметрите на лазерното лъчение за маркиране на инструментална стомана, Международна научна конференция Унитех'06, Габрово, том I, с. 530-532, 2006
7. Латыпов Р.Р., Терегулов Н.Г., Смыслов А.М., Лобанов А.В., Технология лазерной обработки конструкционных и инструментальных материалов в авиадвигателестроении, изд. Машиностроение, 2007

REFERENCES

1. Major Findings of the FIBER LASER REPORT 2009 Press Release March 3, 2009, www.optech-consulting.com
2. Gladkih Ju., Volokonnye tehnologicheskie lazery i ochenka jeffektivnosti ih primeneniya, JeNTI Nauka i obrazovanie, 2008
3. Dianov E.M., Volokonnye lazery, UFN, Konferencii i simpoziumy, t. 174, No 10, p. 1139-1142, 2004
4. Techel A., Faserlaser steigern die Geschwindigkeit vieler Bearbeitungsprozesse, 2007, Maschinen Markt, www.maschinenmarkt.vogel.de/themenkanale/produktion-verbindingstechnik-articles-4617
5. Lazov L., N. Angelov, Osnovni faktori, opredeljashhi kachestvoto na markirovkata na metali i splavi, Mezhdunarodna naučna konferencija Amteh 07, Gabrovo, tom I, p. 102-107, 2007
6. Lazov L., N. Angelov, A. Atanasov, Optimizacija na parametrite na lazernoto lchenie za markirane na instrumentalna stomana, Mezhdunarodna naučna konferencija Unitech 06, Gabrovo, tom I, p. 530-532, 2006
7. Latypov R.R., Teregulov N.G., Smyslov A.M., Lobanov A.V., Tehnologija lazernoj obrabotki konstrukcionnyh i instrumental'nyh materialov v aviadvigatelestroenii, izd. Mashinostroenie, 2007